

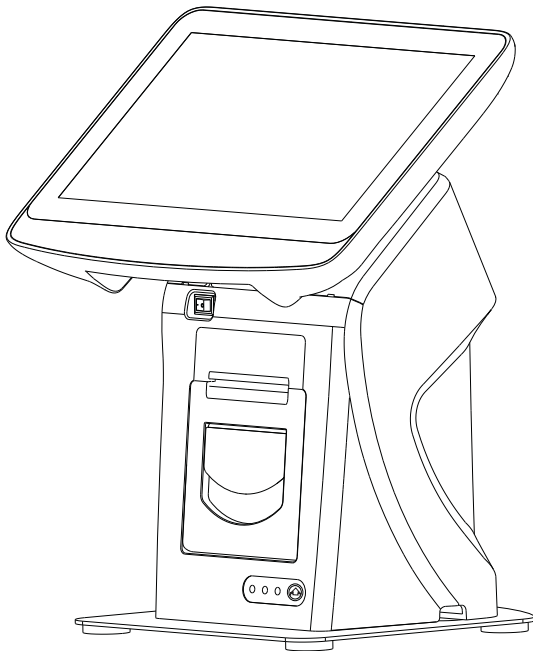

# EC-AM-102-58

## Android POS Terminal

### User's Manual



## 1. Unpacking and Checking

Check the following items in the package, if any of these items is missing, please contact your dealer

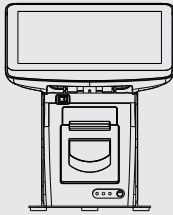

(1) EC-AM-102-58



(2) User manual

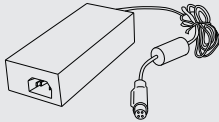

(3) Power adapter

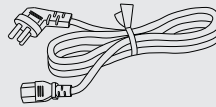

(4) Power cable



(5) Paper roll



(6) CD disk

## Introduction

Read the instructions carefully and thoroughly and save them for later reference. The unauthorized operation may lead to error or accident. Follow all the warnings and instructions in the manual as well as marked on the product. Whenever problem exists, power off and unplug the terminal and contact the authorized reseller / distributor.

## About this manual / Safety statement:

This manual is for EC-AM-102-58 Android POS terminal series, all contents have been validated and reviewed.

EC-AM-102-58 complies with GB4943.1-2011; GB9254-2008

## Warranty

Device must be opened by authorized person or qualified technical engineer. If the product does not operate normally when the operating instructions are followed. Adjust only those controls that are covered by the operating instructions since importer adjustment of other controls may result in damage and will often require extensive work by a qualified technician to restore the product to normal operation.

\*\* The content of this manual is subject to change without prior notice.

## Caution

1. Avoid radio interference
2. Use genuine accessories or spare parts. Use improper spare part may cause damage or malfunction.
3. The power cord of this product is come with ground connection. Make sure the voltage of the electricity is correctly match our power supply.
4. Keep the product, power supply and paper roll in a dry or cool environment. It should never be placed near or over a radiator or heat origin, and should avoid of direct sunshine.
5. Make sure the connection of the cable are connected correctly to the interfaces.
6. Keep your communication device and the integrated printer in the WAN environment, don't connect it to unknown or unrecognized network.
7. The product should use horizontally
8. Unplug this product from the power outlet before cleaning. Do not use liquid or aerosol cleaners. Use a damp cloth for cleaning.
9. Slots and openings on the cabinet and the back or bottom are provided for air ventilation. To ensure reliable operation of the product and to protect it from overheating, do not block or cover these openings. The openings should never be blocked by placing the product on a bed, sofa, rug or other similar surface. This product should never be placed near or over a radiator or heater. This product should not be placed in a built-in installation or kiosk stand unless proper ventilation is provided.
10. This product should never be placed near or over a radiator or heat origin, and should avoid of direct sunshine.
11. Do not locate this product where the cord will be walked on. When the cord or the plug is mangled, please stop using and get a new one replaced. Make sure the old one is far away from the printer, so it can avoid someone who does not know the inside story getting damage.
12. Do not use in locations subject to high humidity or dust levels. Excessive humidity and dust may cause equipment damage or fire.
13. Never push objects of any kind into this product through cabinet slots as they may touch dangerous voltage dots or short out parts.
14. Make sure to turn off the power of the printer whenever repair.
15. Unplug this product from the power outlet and leave servicing to qualified service personnel under the following conditions:
16. When the power cord or plug is damaged or frayed.
  - a) If liquid has been spilled into the product.
  - b) If the product has been exposed to rain or water.
  - c) Power cable is damaged
  - d) Strongly impact

## 2. Button and Interface

### Indicator and buttons

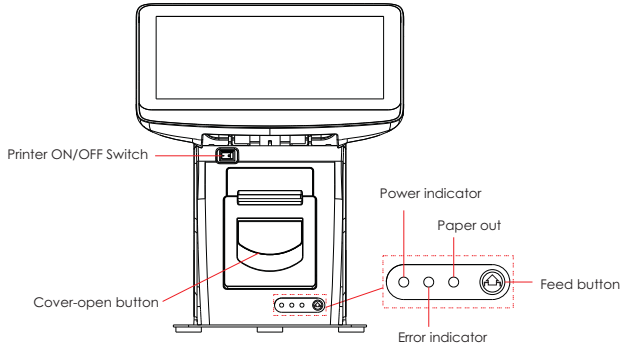

Indicator and button	Description
Power indicator	Shows power status. Blue light when power is on
Error indicator	Red light flash when errors occurs
Paper out indicator	Red light flash when out of paper
Feed button	Paper feed
Switch ON-OFF	On/off button for printer
Cover-open button	Open the cover of the printer to change paper roll
Power button	On/off switch of the terminal
Back button	Return to previous menu

### Host control button

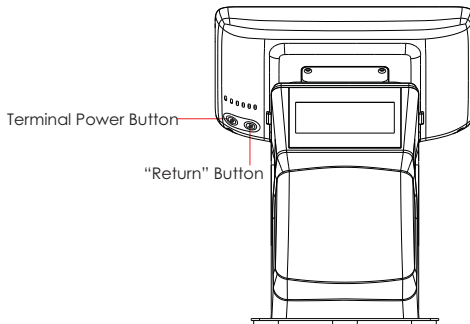

## Host Interface

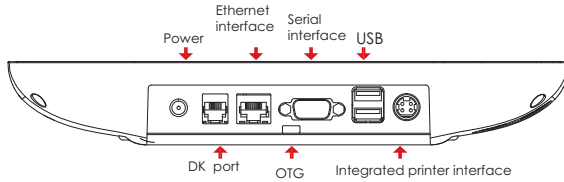

Interface	Description
Power	Power input
Ethernet interface	100M LAN, RJ-45 module connector RJ11 interface, Dual 12V connector cash drawer
Serial port	RS232, D-SUB 9 PIN
USB	Support USB V2.0/1.1
DK port	RJ11 interface, Dual 12V connector cash drawer
OTG	For system adjusting
Integrated printer interface	Reserved for built-in printer

## DK Interface



### Warnings

This interface is only for cash drawer, do not connect with mobile phone or any other device, otherwise will be damaged.

The voltage of the cash drawer should be 12V.

The DK interface is a standard RJ-11, 6 pins socket, output DC 12V / 1A.

Below is the pin assignment:

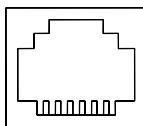

654321

RJ-11

PIN No.	Signal	Flow
1	Ground	Null
2	Cash drawer drive 1	Output
3	Cash drawer switch	Input
4	+12V	Output
5	Cash drawer drive 2	Output
6	Ground	Null

### 3. Paper loading

1. Press the cover-open button, open the cover of the printer.

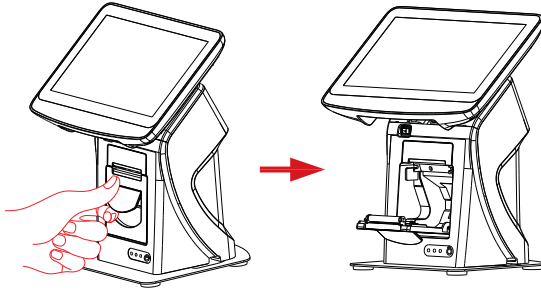

2. Load paper roll into the printer, pull out the paper roll till it pass gap sensor, complete paper loading.

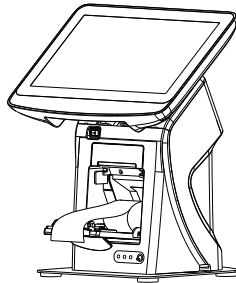

3. Carefully close the cover.

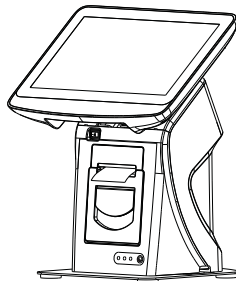

## 4. Power Cable Connection

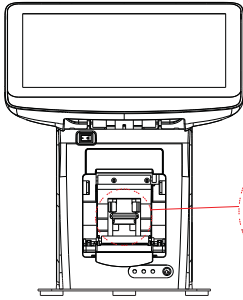

1. Pull the printer open button, there is a host uncover button inside. Drag down the host uncover button until the printer mechanism and the host separates into two parts.

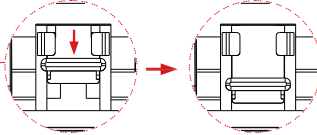

2. Place the cable in between the printer and host, and connect it as shown on the graphic.

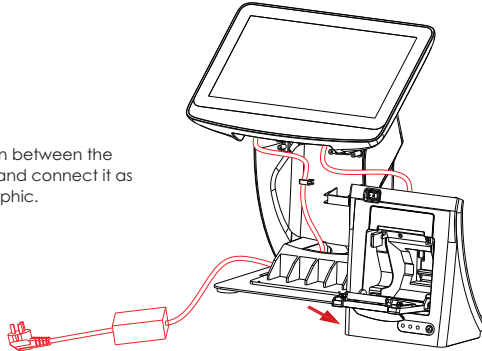

3. Place the printer back into the host, pull up the printer open button then lock it.

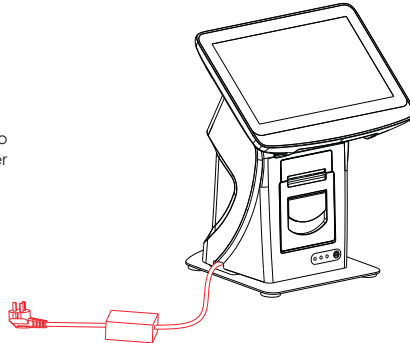

Cabling between cables that connected with host and power cable are the same procedure.



## 5. Troubleshooting

<b>Can not start device, power indicator off.</b>
<ol style="list-style-type: none"> <li>1. Check whether power socket works.</li> <li>2. Check whether power cable plugs tightly.</li> </ol>
<b>Printer keeps beeping, fail to print.</b>
<ol style="list-style-type: none"> <li>1. Check whether the cover of printer is closed correctly.</li> <li>2. Check whether the paper is out.</li> <li>3. Check whether the LED is still on.</li> </ol>
<b>No noise, the printer can not print.</b>
<ol style="list-style-type: none"> <li>1. Check whether the printer cover is opened.</li> </ol>
<b>Receipt is printed unclearly.</b>
<ol style="list-style-type: none"> <li>1. Turn off the power, clean up the print head with medical alcohol.</li> </ol>

## 6. Maintenance

1. To prolong the life of the terminal, make sure that it is well away from heaters, other sources of extreme heat, sunlight; and the surrounding area is clean, dry, and free of dust.
2. The device should never be placed near or over a radiator or electromagnetic.
3. The device should use under a stable power voltage connection with an independent power supply.
4. Do not shake or kick the device.
5. Do not remove or install any integrated device that is not approved from the manufacturer. Do not relocate the device frequently.
6. Remove the dirt of the case with clean and soft cloth. Do not use any chemical detergent.
7. Turn off the power immediately whenever problem occurs. Do not maintain and disassemble the units, contact the authorized person for service.
8. Check the cable connection to make sure they are connected correctly.
9. Disconnect the power when the terminal is not going to use for a period of time.



## **Manufacturer: EC LINE**

Thank you very much for using EC Line product  
For service, please contact [service@ecline.com.hk](mailto:service@ecline.com.hk)

[www.eclinepos.com](http://www.eclinepos.com)



**RoHS CE FC**

The manual content and version are subject to change without prior notice.